

AEON Laser

User Manual

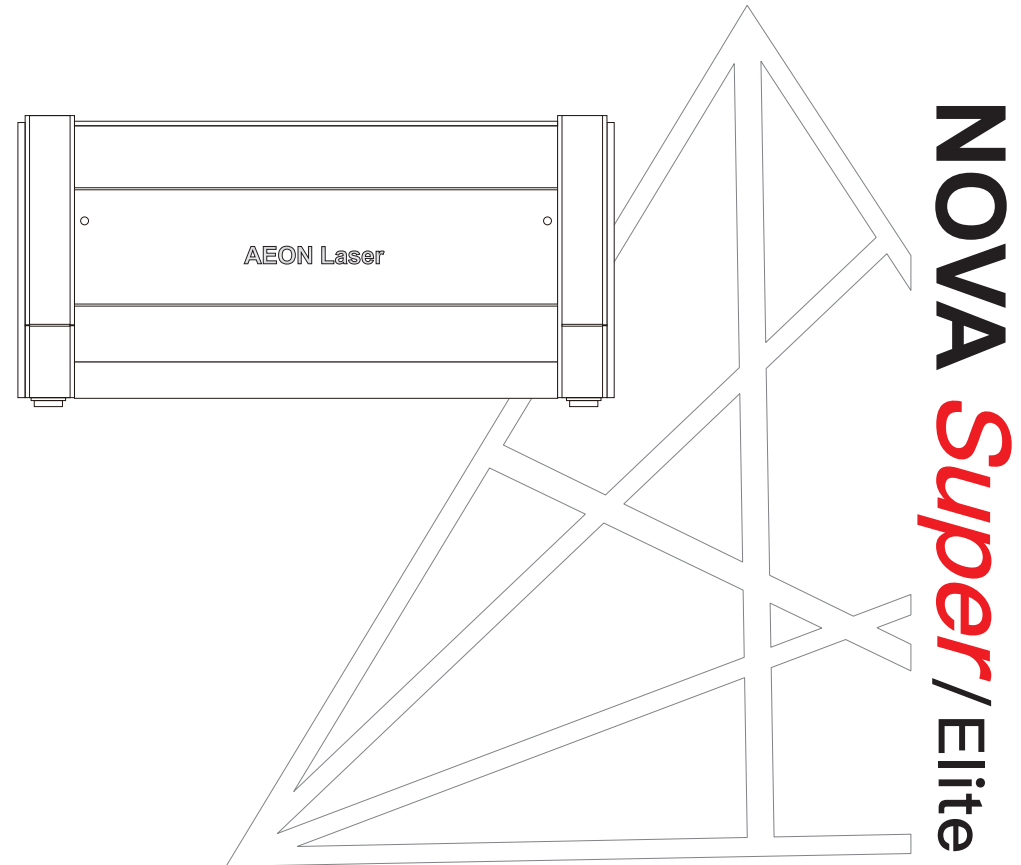

www.aeonlaser.net



NOVA
Super/Elite

Preface

Thank you for choose Aeon Laser. This user manual will help you to get to know how to use our laser machine properly and effectively step by step, also learn how to maintain the machine to get as much from it. The manual is divided into six chapters, including machine general information, safety note, installation guide, operation instructions, maintenance principle and basic trouble shooting techniques. We also take many real object photographs in the manual to help you understand.

Caution:

Before install and operate the machine, please read and follow this Manual carefully. Not following instructions may result in personal injury and/or material damage!

Machine maintenance must use the provided or listed accessories, and it is NOT allowed to replace unspecified parts without our permission. Aeon Laser will not provide free maintenance services for any damage caused by this.

It should be emphasized that the installation must meet with the requirements of AEON Laser. Otherwise the machine will not working properly, resulting in poor performance ,life shortened, maintenance costs increased and even machine damage. We hope every customer could understand these notes before installation and usage. If you encounter any problems during installation, please feel free to contact us.

Welcome to provide us your valuable comments or suggestions, we'll be very appreciated!

Contents

Chapter 1 Safety notice	
1.1 General safety information	1
1.2 Safety Notes	1
1.3 Laser Hazard Warning Labels	2
1.4 Processable materials	4
Chapter 2 Machine Overview	
2.1 Application	5
2.2 Disposal of the machine	5
2.3 Technical Parameters	5
Chapter 3 Installation Guide	
3.1 Packinglist	6
3.2 Machine parts overview	7
3.3 Installation guide	9
Chapter 4 Operation Guide	
4.1 Power on machine	10
4.2 LCD panel operation	11
4.3 Set Language from panel	13
4.4 Optical path alignment	14
4.5 Red beam path alignment	17
4.6 Pulse Setting	19
4.7 Power & Speed Setting	20
4.8 Run your machine	20
4.9 Clean & Replace Lens	22
4.10 Chiller maintenance	24

General safety information

Working Principle of CO2 laser

The word LASER is the acronym for Light Amplification by Stimulated Emission of Radiation. A CO2 laser works by electrically stimulating the molecules within a carbon dioxide gas mixture. When focused through a lens, this highly-intense and invisible beam will vaporize many materials. Depending on the speed and intensity of the projected beam, a CO2 laser may be used to engrave or cut through a wide variety of materials.

Safety Lock System

The laser machine is equipped with a safety lock system utilizing magnetic sensors on the top right corner of the laser working area, The magnetic sensors will deactivate the laser firing when the machine lid is open. After closed the lid, the laser will continue working.



WARNING

- DO NOT operate the laser system if any component of the safety system is malfunctioning.
- DO NOT attempt to remove or modify any component of the safety interlock system.

Safety Notes

- * This laser engraving system contains a carbon dioxide (CO2) laser that emits intensive and invisible laser radiation. Without safety protection measures, it is dangerous to be directly or diffusely reflected radiation!
- * Without safety measures, exposure to laser radiation will have the following risks:
 - * Eyes: Burns cornea Skin: Burns Clothing: Risk of fire
- * There are high voltage and other potential dangers in this machine. Please keep the machine from those who got little knowledge of this machine.
- * All personnel involved in installation, set-up, operation maintenance and repair of the machine, must have read and understood the operation Manual , in particular the "Safety" section.
- * The machine must only be operated by trained and authorized person. The scopes of competence for the different activities in the scope of operating the machine must be clearly defined and observed, so that under the aspect of safety no unclear questions of competence occur. This applies in particular to activities on the electric equipment, which must only be performed by special
- * For all activities concerning installation, set-up, start-up, operation, modifications, maintenance, inspection and repair, the switch-off procedures that may be provided in the Operation Manual must be observed.

- * Preparation, change parts, maintenance and repair activities must only performed with equipment switched off, by trained personel. It is forbidden to perform unauthorized modifications and changes to the machine. It is emphasized, that any unauthorized modifications to the machine are not permitted for safety reasons.
- * CO2 Fire extinguishers should be placed near laser. Do not store any flammable materials in the inside of the device. Particularly leftovers of produced materials have to be removed to prevent fire hazard.
- * These lasers emit invisible radiation, safety glasses should be worn when maintenance the machine for your protection.
- * Do not disable limit switches or safety features as this can invalidate warranties and cause injures and damages.
- * Do not leave the laser unattended when it is working, even a small scraps can ignite and destroy the machine.
- * Before processing the materials, the user must verify whether there are harmful substances produced and whether the filtering equipment of the exhaust system can filter harmful substances. When selecting filters and exhaust systems, consider the country's and regional dust, mist and gas thresholds. (Do not exceed the maximum concentration value in the workplace.)
- * Keep the machine in dry place, non-pollution, non-concussing, non-strong electricity, non-strong magnetic field etc. environmental temperature should be 5-40°C, environmental humidity should be 5-95%. (no condensed steam).
- * The laser will generate electromagnetic, which should be far away from EMI sensitive equipment.
- * Do not turn on the machine when the input voltage is unsteady or mismatch.

Laser Hazard Warning Labels

- * Manufacturer's Label

This label is located at the right-back side of machine. All the product information such as Serial Number, Model Numbers, Laser Power and Electric power can be found here. Before requiring any further tech support, always provide the service person with the information on this label.

CDRH Label

This label indicates the class level of CDRH.



Laser Path Label

This label indicates the laser path. Please take extra caution of this area when maintaining the machine



Laser Path Hazard Label

AEON laser equipment is very safe under normal working conditions. Laser path warning labels will be affixed to possible laser paths. When operators approach these paths, ignoring warning labels is prohibited. They should be careful about possible injuries while the machine is running.



Laser Path Label

This laser indicates the laser path. Take extra care of this area when engraving/cutting, avoid direct exposure to visible or invisible beam.



Laser Hazard Label

This label indicates that there is invisible laser radiation, usually can be found on the outside body of the machine. Pay attention to the laser radiation, avoid exposure to beam.



Safely processable materials

Laser machines use high heat to cut or etch a given material. Some materials can be processed very well, and some materials do not. It's important to know the material you're using, as some, like PVC, are easy to cut, but can release chlorine, which is unhealthy. Below is a list of materials to use as a guide. New materials come out every day, if you are not sure if your material is safe for laser processing, please contact us and we will try and determine if it is safe to use the laser for processing.

Material	Engraving	Cutting	Marking
Composite Material	Label Film	●	●
	Brick Tile	●	●
	Carbon Fiber/Glass Fiber	●	●
	Ceramics	●	●
	Pearl Foam Board	●	●
Natural Inorganic Materials	Gemstones		●
	Shell	●	
	Stone	●	●
	Glass	●	●
Natural Organic Materials	Leather	●	●
	Wood	●	●
	Elastomer Rubber/Silicone	●	●
Foam	EVA/Silicone	●	●
	Ceramic/Metal Foam	●	●
Paper Base		●	●
Plastic	PMMA	●	●
	ABS	●	●
	PDMS	●	●
	PEEK	●	●
	PLA	●	
	PET		●
	POM	●	●
	PC/PA/PE/PP		●
Fabric/Textile Fabric	Cotton	●	●
	Felt	●	●
	Denim	●	●
	Cashmere	●	
	Nylon Fabric	●	
	Polyester	●	
	Aramid Fiber	●	
Metal	Brass		●
	Stainless Steel		●
	Titanium		●
	Coated Metal		●
	Anodized Aluminum		●

* CO2 lasers can engrave or mark coated metal. For bare metal, it is not recommended, as the laser light might reflect back into the laser path, causing permanent damage to the optical parts. However, there are CO2 laser marking solvents available on the market. After applying these solvents, it is safe to use a CO2 laser for marking.

Application

Aeon laser system is used for engraving and cutting of signs, stamps, etc. A wide variety of materials can be processed, such as rubber, acrylic, coated metal, tin, special steel, anodized aluminum, cork, cardboard, glass, leather, marble, plastics and wood.

- * The engraving process must only be performed with a perfectly adjusted machine.
- * For cutting applications with 40W the use of the cutting table is absolutely necessary.
- * Use of the system in other areas is against the designated use. The manufacturer does not admit liability for damage to personal and/or equipment resulting from such use.
- * The system must only be operated, maintained and repaired, by personnel that are familiar with the designated field of use and the dangers of the machine!
- * Non-observance of the instructions for operation, maintenance and repair described in this Operation Manual excludes any liability of the manufacturer if a defect occurs.
- * Caution when processing conductive materials (carbon fibers), Conductive dust or particles in the ambient air might damage electrical components and lead to short circuits. Bear in mind that those defects are not warranted.

Disposal of the machine

Do not dispose the machine as waste, electronic devices have to be disposed according to the regional directives on electronic and electric waste disposal.



Technical Parameters

Model	Super10 / Elite10	Super14 / Elite14	Super16 / Elite16
Working Area	1000*700mm	1400*900mm	1600*1000mm
Machine Size	1500*1210*1025mm	1900*1410*1025	2100*1510*1025
Laser Tube	80W/100W RF30W/60W ; 80W/100W	100W/130W RF30W/60W ; 80W/100W	130W/150W RF30W/60W ; 80W/100W
Electric Up&Down	200mm Adjustable	200mm Adjustable	200mm Adjustable
Machine Net Weight	450Kg	520Kg	620Kg
Machine Packing Weight	530Kg	610Kg	730Kg
Packing Size	1600*1320*1225mm	2000*1510*1225mm	2200*1650*1225mm
Input Voltage	220V AC Single Phase 50Hz/60Hz, Optional for 110V AC Single Phase 50Hz		
Rated Power	2600W		
Engraving Speed	2000mm/s ; 1200mm/s		
Acceleration Speed	5G		
Cutting Speed	800mm/Second		
Laser Optical Control	1-100% Set by Software		
Minimum Engraving Size	Chinese Charator 2.0mm*2.0mm, English Letter 1.0mm*1.0mm		
Max Scanning Precision	1000DPI		
Locating Precision	<=0.01		
Cutting Thickness	0-30mm(depends on different materials)		
Engraving Software	RDWorks/LightBurn		
Graphic Format Supported	DSP/PLT/BMP/DXF/AI/DWJ etc.		
Compatible Software	CorelDraw/Photoshop/AutoCAD/All kinds of Embroidery Software		
Worktable	Honey Comb+Aluminum table		
Auto Focus	Integrated Autofocus		
Red Dot Positioning	Yes		
Rotary Device	Optional		
Built-in WIFI	Optional		



Accessories List packing with machine:

- | | | |
|--------------------------|----------------------|-------------------------|
| 1 LAN Cable 5M X1 | 2 USB Cable 3M X1 | 3 Allen Wrench X 1set |
| 4 Honeycomb Table X1 | 5 Accessories box X1 | 6 100F Foot Wheel X4 |
| 7 Air exhaust pipe 5M X1 | 8 Key Switch X2 | 9 Exhaust Pipe Clamp X2 |
| 10 Power Cable X1 | 11 Lens tool X1 | 12 U Disk X1 |

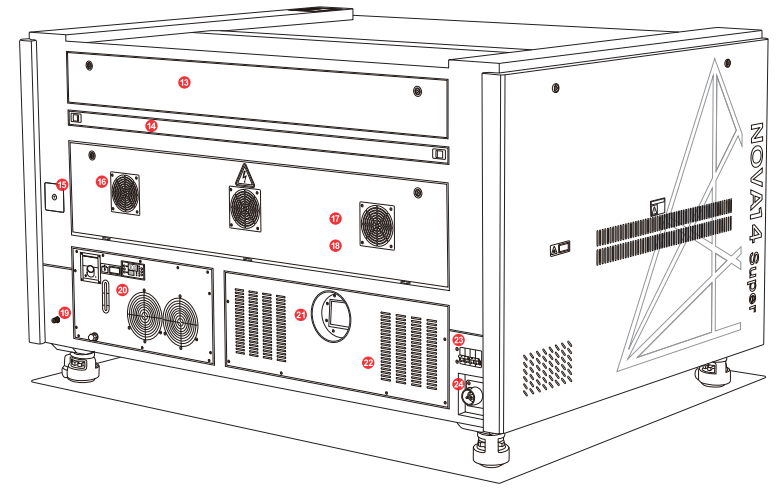
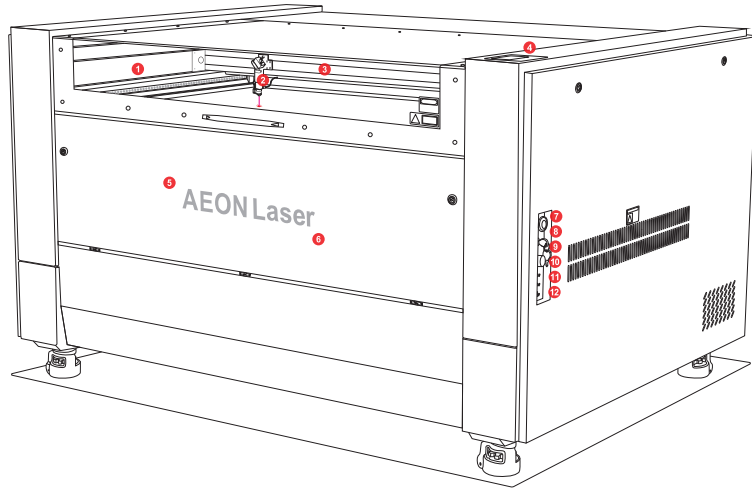

- 1 Dust-proof Transmission Belt
- 2 Integrated autofocus laser Head
- 3 Sealed Dust-Proof Guide Rail
- 4 Control Panel
- 5 Active airflow fan
- 6 Waste Collection Device
- 7 Emergency Stop Button
- 8 Key Switch
- 9 Air blow Adjustment Knob
- 10 U DISK Port
- 11 USB port
- 12 LAN interface

- 13 Synchronous Drive Shaft
- 14 Material Pass-through-door
- 15 WIFI
- 16 Cooling Fan
- 17 RF Metal Tube
- 18 Sealed Co2 Glass Tube
- 19 External Air Compressor Port
- 20 Built-in Industrial Chiller
- 21 Built-in Exhaust Fan
- 22 Built-in Air Compressor
- 23 Air Break Switch
- 24 Power Cable Interface

Setup and installation guide

This laser machine with highly compact design, it has integrated a water cooling system and an air assist system. It is very simple to install. You don't need to prepare a bucket or an air pump.



1. Open the chiller water inlet cap, add about 3L of pure water (1070 size with about 2L)



2. Open the fan cover, put air hose through the cover, fix it on the fan, close the cover and fix it.



4. Open the side doors on both sides of the machine, find the fixing pin in the Y-axis direction and remove them.



3. Plug in the power cable



5. Open machine lid, cut off the X-axis fixing strip that binds the key and other accessories (near laser head).

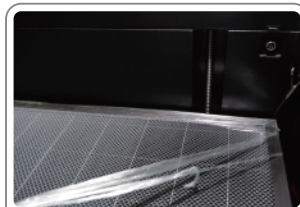

6. Remove the protective film wrapped around the honeycomb platform.

1. Power on Machine

Turn on the 2 power switch, Release the emergency stop button 7, turn on the key switch 8

Note: When installing for the first time, do NOT run the machine immediately after powering on. Wait a minute or two for the water cooling system to circulate to fill the laser tube with pure water.

2. Install Software (RDWorks V8)

Insert the accessory U disk 12 into the computer; double-click to run the RDWorks Setup file.

3. Connect Machine to Computer

1. Connect by USB Cable

Insert the data cable 2 into the USB port 1, and connect the other end to the other end to the computer, run RDWorks, set "Device -USB:Auto", and the software will automatically determine the connection interface with the device.

When there are multiple laser devices connected to the computer, click [Add] to add a new machine. When you need to use one of those machines, click the check box to choose it.

Click [Add] or [Modify], a dialog box will pop up. After adding or modifying, you can click [Test] to check whether the connection with the device is successful. Find the currently connected device and select the machine with the corresponding IP address from the list.

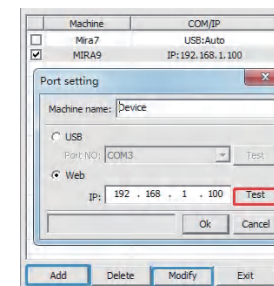

2. Connect by LAN cable

Insert the LAN cable into the interface and the other end to the router, click the [Menu] button on keyboard panel, press the arrow keys to select and click to enter the IP setting page; press the key to select the option to be modified, press the arrow key to modify the value, press the [Enter] key to confirm the modification and return to the previous page.

In RDWorks software bottom right [Device] part, click [Setting], click [Add] or [Modify] to enter the same IP of the machine, and click [Test] to check whether the connection with the device is successful.

3. Connect by Wifi

Connect the computer to the WIFI of the machine, click [Setting] in RDWorks software [Device] part, click [Add] or [Modify] to enter the same IP shown on the machine panel, and click [Test] to check whether the connection with the device is successful.

Operation Panel Instruction

After power on the machine, the panel will display the following interface:

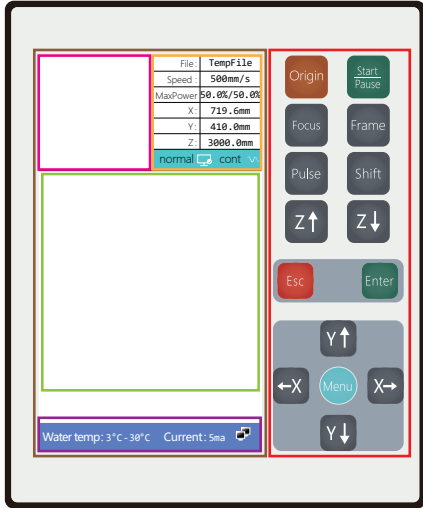

- Keypad operation area
- LCD display area
- Layer display area
- Processing status display area
- Parameter setting menu area
- Preview display area
- Machine status display area

Keypad function description

Shift : Switch key, used for key combination switch of special functions

Menu : User parameter, vendor parameter, language setting etc.

Shift + Start/Pause	: Reset	Shift + Pulse	: Pulse Intermittent /continuously
Shift + Frame	: RAM /U Disk file management	Shift + Z↑	: Switch to tube 2
Shift + Focus	: Switch to tube 1	Shift + Z↓	: Power/speed

Origin : Set Origin

Start/Pause : Start/Pause

Focus : Autofocus

Frame : Frame

Pulse : Pulse

Esc : Return to the previous menu, cancel parameter settings, etc.

Enter : Confirm

Z↑ Z↓ : Move Z axis up/down

←X X→ : Used for X-axis movement and menu parameter value change

Y↑ Y↓ : Used for Y-axis movement and menu parameter value change

LCD function description

Layer display area: Display the layer parameters of the current file or preview file, the parameters from left to right are: layer number/color/speed/maximum power; In the file management state, the graphic preview of the selected file is displayed. During the operation of the panel, the operation prompts and the execution command status of the machine are displayed.

Processing status display area: display the file number, speed and maximum energy of the current processing file; the coordinate value of the current position of the laser head; the intermittent or continuous motion status display.

Parameter setting menu area/preview display area: Display the settings and prompts of all parameter control menus; Show the processing file image during processing.

Machine status display area: Display the real-time status of the equipment: progress bar, water temperature, voltage and communication connection status.

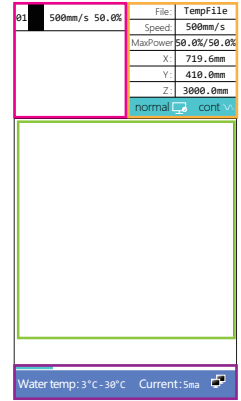

Set Panel Display Language

Before setting the panel parameters, first set the language you are familiar with (default language is English).

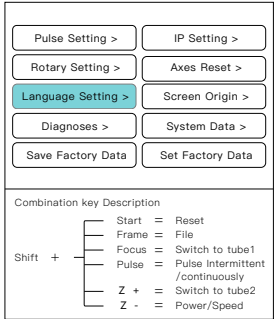

Press **[ESC]** to enter parameter setting page; Press **[↑]** **[↓]** to **Language setting >** option, press **[ENT]** to select.

Press **[↑]** **[↓]** to move the option frame to the language you are familiar with, press **[ENT]** to choose and **[ESC]** to exit.



Detect & Debug Laser Path

Operations to be mastered before checking and debugging the optical path: PULSE

Under the machine power-on status, Press and hold **[ESC]** button and press **[ENT]** button to switch the first reflector from the red light position to the tube 1; press **[ENT]** to fire. When you need tube 2 to pulse, press **[ESC]** + **[Z↑]** to select tube 2 in the same way as above.

Note:

Double laser source Super model need to select laser tube first; Single laser tube Elite model can **[ENT]** by dirctly presses **[ENT]** button.

Laser Path Alignment

Each Aeon laser has gone through a standard inspection process before delivery, including the calibration of the laser path. However, during the long-distance transportation and handling of the machine, some deviations in the optical path may occur, which would affect the machine's performance. Taking the Super Nova as an example, please refer to the following method to check and adjust the laser path:

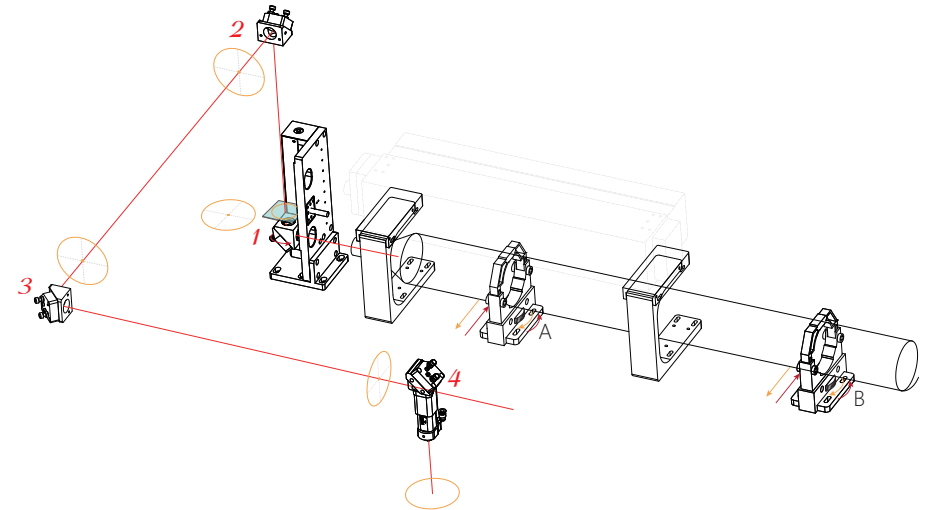

1. Place a piece of small acrylic sheet (larger than the aperture) on the first reflector (or attach multiple layers of paper-based tape); switch to the glass tube laser to pulse, ensure that the dot burned by the laser beam is located in the center of the first reflector, as shown above: If the dot position is offset, the adjustment measures are as follows:

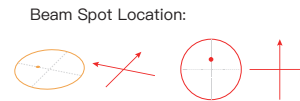

Beam Spot Location: Adjust Method: B **(↷)** **(↶)** or A **(↷)** **(↶)**

Beam Spot Location:

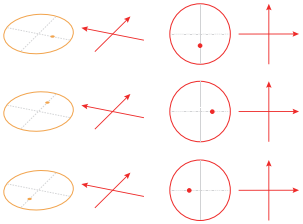

Adjust Method:

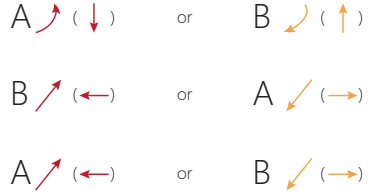

2. Facing the beam exit of #2 reflector, cover with acrylic sheet or multi-layer paper-based tape; Pulse and ensure the burned dot is located in the center of the mirror.

If the dot position is offset, adjustment measures are as follows:

From the other direction, you can see that there are two upper and lower adjusting nuts on the first reflector. Looking directly at the second reflector, the upper nut of the first reflector adjusts the level of the light spot on the second reflector exit plane, and the lower nut adjusts the second reflector. The left and right sides of the exit plane of the two mirrors. E.g:

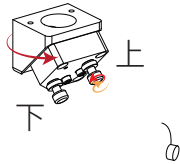

Beam Spot Location:

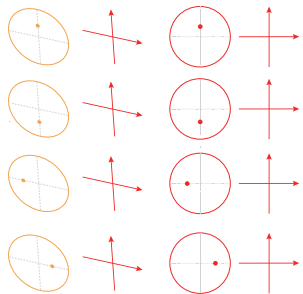

Adjust Method:



3. Facing the laser beam entrance of #3 reflect mirror, cover beam entrance with acrylic sheet or multi-layer paper-based tape, continue to pulse with the glass tube, make sure that the spots burned by the laser at the proximal and distal ends of Y axis overlap and are centered on #3 reflect mirror.

First move the Y-axis to the 0 point coordinate position (the top of the working platform), and Pulse with glass tube. If the spot position is offset, adjust the adjustment nut of the second mirror, the adjustment method is the same as step 2. Then move the Y-axis to the farthest point and pulse, check if the far end spot is overlap with the near end spot, if there is any deviation, adjust the second mirror adjustment nut, the adjustment method is the same as step 2; then return to the Y-axis nearest position to verification again, till the 2 spots overlap.

4. Facing the laser beam entrance of the 4th reflect mirror, cover beam entrance with acrylic sheet or multi-layer paper-based tape, continue to pulse with the glass tube, make sure that the 4 spots on the four corners of the working table all overlap and are located in the center of the 4th reflect mirror. If the dot position is offset, the adjustment measures are as follows:

Note: Although the 3rd reflect mirror with the same structure as other mirrors, it is installed horizontally (to ensure the light entrance & exit at the same level), thus the upper and lower positions of the adjustment nut have changed. Please pay attention to the adjustment direction.

First move the 4th reflect mirror to the upper left of the work table, pulse with glass tube, If the spot position is offset, adjust the optical adjustment nut of the 3rd reflect mirror. Please note that the upper screw adjusts the left and right directions of the spot on the 4th reflect mirror, and the lower screw adjusts the up and down direction. Adjust the spots on four corners of the working table in order (According to the order of distance from the laser tube from near to far), make sure that the 4 spots on the four corners of the working table all overlap and are located in the center of the fourth reflect mirror.

Beam Spot Location:

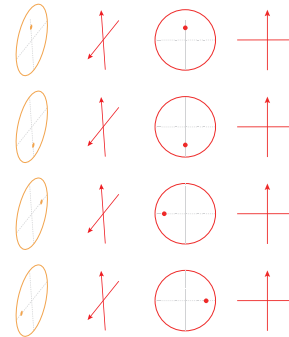

Adjust Method:

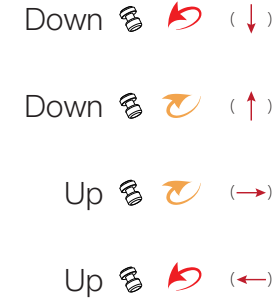

5. Before adjusting the fourth reflector, first check if the red dot spot overlap with the laser spot, if there is any offset, the adjustment method is as follows:



Find red dot component on the back of first mirror (as shown below). Use a 2mm Allen key to adjust the adjusting nut circled in the photo. The upper left nut adjusts the upper left and lower right directions, the upper right nut adjusts the upper and lower directions, the lower left nut adjusts the left and right directions.

Red dot position:	Adjust method



6. After finish adjusting the red light, adjust the fourth reflect mirror, stick the paper-based tape on the laser head nozzle, pulse and remove the tape to check whether the spot is in the center of the nozzle contour and check whether the spot shape is round or not.

If there is any deviation, adjust the adjustment screw of the fourth reflect mirror and repeat sticking the tape to do spot shot inspection until it is centered and in round shape. The specific adjustments are as follows:

Red dot position:	Adjust method
	Up Down
	Up Down
	Up Down
	Up Down

Note: Before adjusting the reflect mirror, adjust the fastening nut on the lower edge of the screw to ensure that the adjustment screw has enough adjustable space; after finishing the adjustment, remember to lock the fasten nut to avoid the loosening of the adjustment screw and the reflector during the high-speed operation of the machine, which may cause the offset of optical path.

7. So far, the optical path of the glass tube laser has been adjusted. The adjustment of the optical path of the RF tube laser does not need to adjust the four mirrors again, because once the mirror frame is adjusted, it means that the optical path of the glass tube laser that has just been adjusted has been deviated. It is known that the laser only needs to adjust the position of the laser tube, make the optical path overlaps with the optical path of the glass tube and the red light, to complete the optical path adjustment of the entire super model. The specific adjustments are as follows:

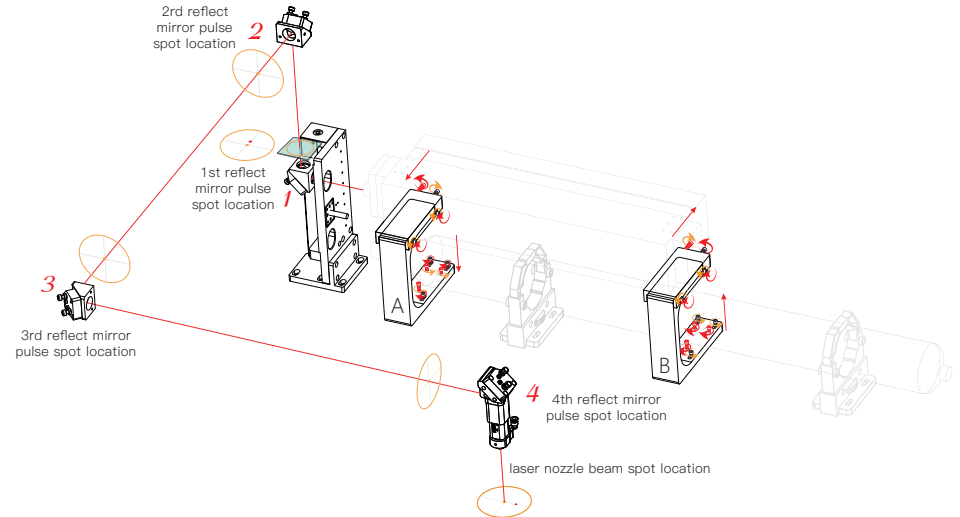

8. Place an acrylic piece with larger diameter than the aperture (or stick a multi-layer paper-based tape) at the light outlet of the first reflector; switch to the glass tube laser to PULSE and then switch to the RF tube laser to PULSE, check whether two spots are overlap. Then stick paper-based tape on the nozzle of the laser head and pulse with RF tube. Remove the tape to check whether the perforation is located in the center of the nozzle contour and whether it is in round shape; if there is any deviation, such as

point deviation, the adjustment measures are as follows:

Spot location: Adjust method:

1st reflect mirror spot 4th reflect mirror spot

Method A: Adjusting screws on the back side of the bracket. Method B: Adjusting the height of one end of the laser.

Notice:

To adjust the horizontal position of the bracket, first loosen the fastening screws on the side of the bracket, Push one of the two adjusting screws on the back side (as shown in the pic)and pull the other one. If need to push, loosen the pulling-screw first and then tighten the pushing-screw. If need to pull, loosen the pushing-screw first and then tighten the pulling-screw. After adjustment, pay attention to tighten the fastening screws. Adjust the upper and lower positions in the same way. First loosen the opposite direction screw to leave an adjustable amount, and then adjust the direction screw to the proper position. If the previous reverse direction screw has left too much adjustment, then tighten the opposite direction screw to fix the position.

Pulse Setting

Under normal circumstances, the perpendicularity of the laser determines the cutting edge effect of the material, especially for thicker materials. We can check the verticality of the laser by "Pulse".

Press **ESC** to enter the Parameter setting menu, press **↑**/**↓** to move to **Pulse setting >** As shown in the right photo, press **ESC** to enter next level menu.

Combination key	Description
Start	= Reset
Frame	= File
Focus	= Switch to tube1
Pulse	= Pulse intermittent /continuously
Z +	= Switch to tube2
Z -	= Power/Speed

Press Menu to change the modified Item
Press the arrow buttons to modify
Press Enter to confirm

The Pulse mode is divided into continuous pulse and discontinuous pulse (Pulse). Continuous means as long as you are pressing the pulse button on the PULSE button, the laser will keep firing; Under Pulse mode (discontinuous pulse), you can set the firing time of each time press the pulse button, and it has nothing to do with the duration of pressing the button. The default value of Pulse time is 100ms, and changing to 0 is equivalent to continuous pulse (firing).

Prepare a transparent acrylic block about 30mm square and 8~10mm thick, and pulse two spots in the X direction and Y direction respectively. Through the acrylic section, observe whether the two point-shot perforations are parallel and perpendicular to the acrylic plane. If the X direction of the perforated line is not vertical, move one end of the laser tube in or out horizontally; If the Y direction is not vertical, adjust the height of one end of the laser. The adjustment method is the same as the previous optical path adjustment.

Power and Speed

Press **ESC** + **Z+** at the same time, the power and speed adjustment option will display:

Notice:
The modification of this working speed parameter only affects the moving speed when pressing the direction keys, and the modification of this power parameter only affects the pulse power.

Press Menu to change the modified Item
Press the arrow buttons to modify
Press Enter to confirm

After completing the above parts, congratulations!!!
You've prepared your Laser machine!!!

Try Your Aeon Laser Out!!!

Find a piece of material suitable for processing and place it on the worktable, move the laser head to the upper right corner of the material, press **Home** button to set the positioning point, and press **Auto** to do the auto focus.

Open the Control software (RDworks, LightBurn or Ruida plug-in directly in Coreldraw or Illustrator etc) that supports Ruida controller on the PC end, and insert the designed file (vector or bitmap), or do simple design and typesetting directly in control software; after setting the processing parameters, click to download or send to machine, and you can also click to start directly if machine already connected to PC.

Press and hold **Shift** + **Home** key on the control panel to enter the file management interface, as shown in the right photo:

Here you can find all the files sent from the PC to save in the press the **Up** / **Down** to select file, you can preview the file size and file content in real time; click **Start** to start processing the file.

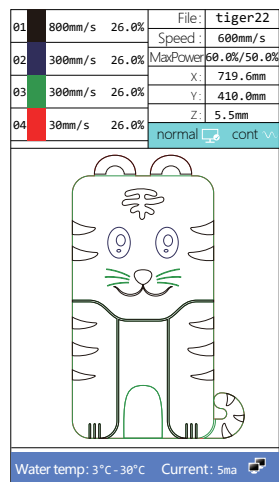
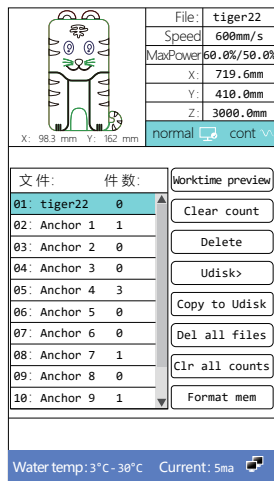

You can also press **Enter** to preview the details of the selected file, to browse the file's layering parameters, etc. (as shown on the left), then press **Enter** to access the layer selection area, and press buttons **Up** / **Down** to select and check the parameters of each layer.

Press **Enter** to access the parameter modification page of the selected layer, or directly switch layers in this page to modify parameters (as shown on the right). After finishing the parameter adjustment, press **Start** to start processing.

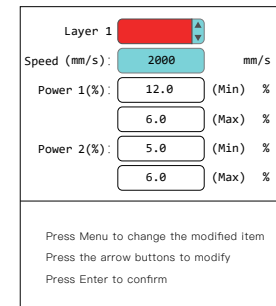

There are many factors that affect the cutting and engraving quality. To reach to ideal results, we need to set correct parameter, accurate material tolerance compensation and a clean and smooth optical path. For a sudden abnormal processing results, you have to think about three questions:
1) Are the focus lens and reflecting lens clean?
2) Is the material deformed? or the same specific materials with different thickness tolerances?
3) Is the laser output power decreased?

Usually, the first one and the second one mostly occur. Therefore, it's required to maintain and clean the lens regularly and timely during use, in addition, commonly used materials should be properly and orderly stored.

Cleaning and maintenance your lens

This series is equipped with 2.5" focus length as standard lens, and 2" and 4" lenses are optional. The removal, cleaning, and replacement of the focus lens are shown as follows:

Removal and cleaning of 2.5" focus lens:

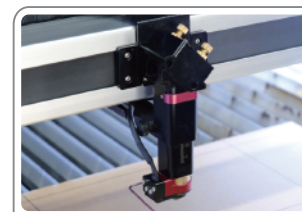

1.Remove the two set screws on the laser head focus sensor with a 1.5mm allen key.

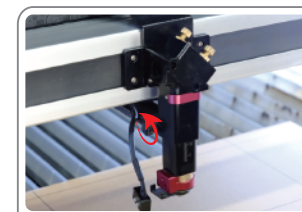

2.Carefully pull out the focus sensor, and loosen the fastening screw in the direction of the arrow



3. Pull out the lens tube and remove the air hose.



4. Remove the nozzle and use the attached tool to remove the lens fastening ring.



5. Place the disassembled lens tube, lenses and all accessories on a piece of clean and dust-free cloth.



6. Clean the disassembled items with dust-free swabs/wipes/cloths and highly concentrated.

Install 2" focus lens



1. Remove the brass attachment on the lower edge of the lens tube.



2. Orderly place the lens tube, lens, lens fasteners, and brass attachment on a piece of dust-free cloth.



3. Install the lens & fasteners from the bottom of the lens tube in the order as above pic shows.



4. Fasten the lens in place with the attached tool, and install the brass attachment.

Install 4" focus lens



1. Remove the fastening screws at the left and right ends of the 4" lens bracket with a 1.5mm hexagonal wrench.



2. Take out the 4" lens holder



3. Install the lens on the lens holder with the convex side facing up, and replace the lens tube.



4. Adjust the movable lens tube, to make sure scale 10 to align to the lower edge of the upper fixed lens tube.

Chiller Maintenance

This series is equipped with 5000/5200 built-in water chiller to ensure the machine's stable working. Therefore, it is necessary to routinely maintain the water source and piping of the water chiller.

Most of users fill the water chiller with pure water, since it is economical and easy to get. However, ordinary distilled water or deionized water will become weakly acidic liquid after a period of time, which will cause rust on metal parts; in addition, hard water contains a large amount of alkaline substances, which become scale after heating and separation, which adheres to the heat dissipation. If the metal surface inside the device cannot be cleaned regularly, the thick scale will seriously affect the function of the cooling system.

Therefore, if you choose pure water, it is recommended to clean the water tank and change the water every 6 months. If the frequency of use is high and the load is heavy, the water changing time can be appropriately shortened and the water changing frequency can be increased. Otherwise, impurities such as calcium and magnesium in pure water will adhere to the inner wall of the laser tube and affect the laser energy.

Draining steps:

- ※Open the cap for the water inlet
- ※Place a proper container below the water inlet
- ※Unscrew the cap for the water inlet
- ※Draining the water in the laser tube with auxiliary equipment such as air compressor



Tips to share:

Three years ago, we added a heat transfer fluid in the water tank of our test MIRA7 machine in the and the fluid's working temperature is at -20°C – 105°C . Described as the introduction, the fluid has good thermal conductivity and fluidity, excellent freezing and boiling resistance, and mitigation and dirty resistance, will not generate scale, can keep the water loop stable, and prevent the corrosion of water cooling parts. Moreover, it has outstanding heat transfer capacity and stable heat dissipation capability is free maintenance for 5 years, and can prolong the maintenance interval to a great extent.

Fortunately, the laser machine has worked for three years at the temperatures from -8°C to 43°C , its performance is still stable as before, and there are no impurities and limescale in the laser tube.

The Aeon laser MIRA 7 has no function of refrigeration, but the water thermometer always indicates a range of 28°C – 36°C for a long term, it's a good reference.

For any technical support request/feedback/suggestions, pls mail us: info@aeonlaser.net